

LEBLxx543055C

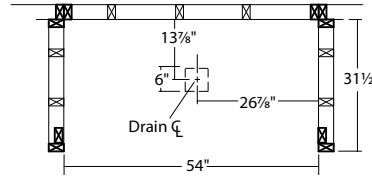

⊠ = required stud location
⊞ = suggested stud location

LEBLxx542755C

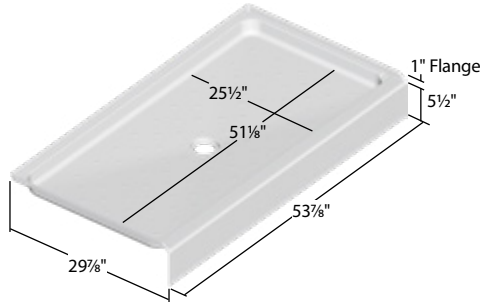
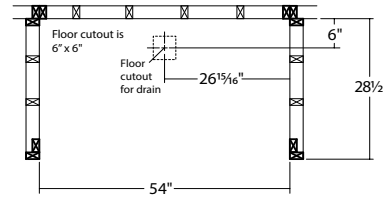
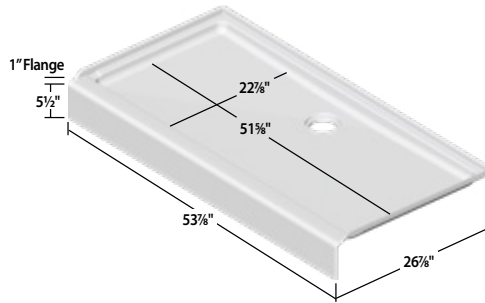

⊠ = required stud location
⊞ = suggested stud location

5427 Stud Layout
Fits most standard 54" x 27" shower walls.

LEBLxx542755(L/R)

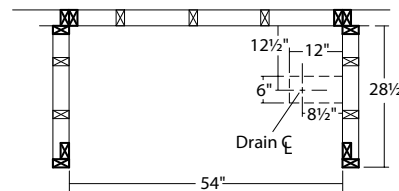
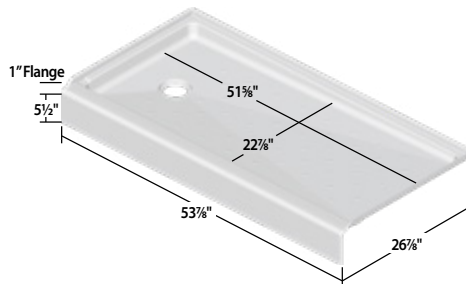

⊠ = required stud location
⊞ = suggested stud location

5427 Stud Layout
Fits most standard 54" x 27" shower walls.
RH drain shown, reverse for LH drain

LEBLxx483055C

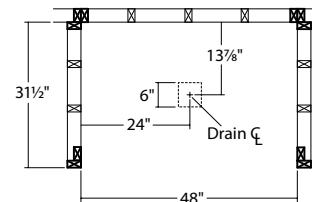
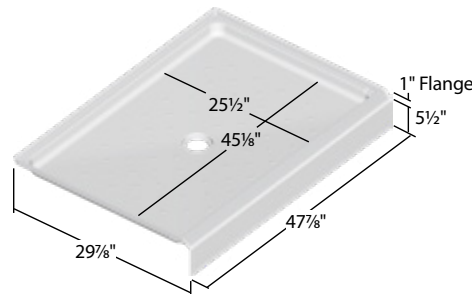

⊠ = required stud location
⊞ = suggested stud location

Max Door Threshold Width 3"

Subject to manufacturing tolerance of [+] or [-] 1/8"

TOOLS YOU WILL NEED:

Level
Square
Jig saw
Tape measure
Pencil
Power Drill
Safety Glasses
Caulk Gun

SUPPLIES YOU WILL NEED:

1-5/8" Stainless Steel Screws
Shims
Construction Adhesive
Mortar compound (optional)
Drain assembly
100% Silicone for Drain

COMPLIANCE CERTIFICATIONS:

ANSI Z124.1 AND CAN/CSA-B45
CAN/ULC S102.2 FLAME-75
SMOKE DEVELOPED-485 CODE

IMPORTANT

- Allow base to reach room temperature before installation
- Before you begin determine appropriate product reference (Page 1)
- Read installation instructions carefully before starting project
- Keep instructions for warranty information
- Do not use plumber's putty. May result in product failure. Use a high grade silicone caulk for all necessary locations
- Do not use sulfuric acid to unclog drain. Will cause product failure and void warranty. Use plunger or snake to clear obstruction.
- **If installing a door, you must build wall flush with base to accommodate jambs**

Before installation, peel away protective film to ensure correct color.

STEP 1. PREPARING ALCOVE

- a. Strip alcove to bare studs.
- b. Shower stud pocket should be constructed as shown on page 1. Studs should be plumb and square to sub-floor.
- c. Sub floor must be clean, smooth, and level (Fig 1). Do not install shower base on open floor joists.
- d. Cut hole in sub floor as shown on page 1 to accommodate drain (not included).

STEP 2. TRIAL FIT BASE

- a. Trial fit base in prepared alcove. With base sitting flat on floor ensure base is level (Fig 2).

NOTE: If sub-floor is not level, use shims or a leveling compound (smooth mortar) or a similar quick-setting compound specifically made for leveling floors. This fully supports and levels base.

- b. Remove base from alcove.

STEP 3. INSTALLING BASE

- a. Follow manufacturer's instructions for installing drain.
- b. Apply construction adhesive to all feet (and shims if needed) (Fig 3 & 4).
- c. Carefully set shower base in alcove. Avoid sliding base, which will smear adhesive.
- d. If needed, shim between nail flange and stud(s) to create a tight fit.
- e. Once leveled, screw nail flange to all studs (Fig 5).

IMPORTANT

- **Failure to adhere feet to subfloor and screw flange to all studs will void warranty**
- **If installing a door, you must build wall flush with base to accommodate jambs**

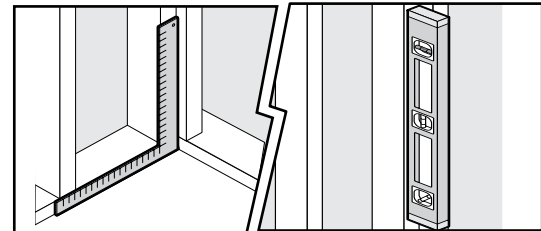

FIGURE 1. Check that studs are plumb with sub-floor/base.

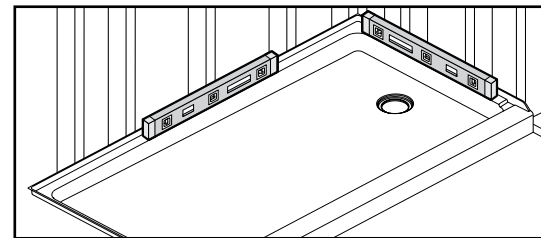

FIGURE 2. Check to assure base is level.

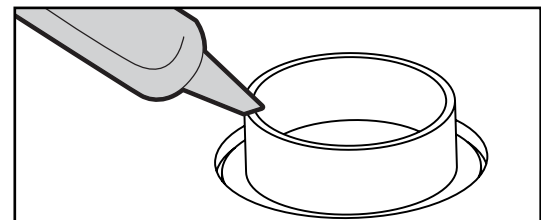

FIGURE 3. Apply construction adhesive to all feet.

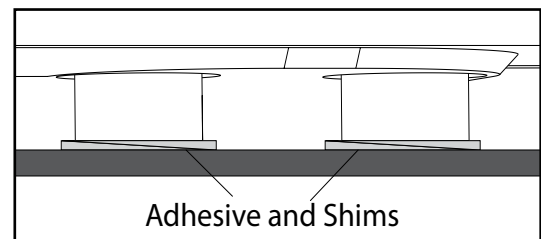

FIGURE 4. If needed, place shims under feet into adhesive to level base.

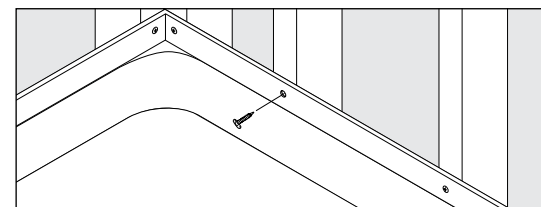

FIGURE 5. If needed, shim between nail flange and stud(s) for tight fit. Screw flange to all studs.

DO NOT RETURN PRODUCT OR CONTACT STORE! FOR QUESTIONS OR CONCERNS

please call or e-mail our customer support team

1-800-458-9036

lyonssupport@lyonsindustries.com

CLEANING

- Do not use any abrasive cleaners or metal scrapers.
- If drywall mud or plaster gets on your bathtub, it may be carefully removed with a wooden scraper made from a piece of scrap wood.
- Adhesive may be removed with mineral spirits.
- Ideal cleaners are Soft Scrub Gel® or Comet Gel®.
- Hair dye may stain. Do not use.
- Do not use sulfuric acid to unclog drain, use plunger or snake to clear obstruction.

WARNING: Some cleaning products are not suitable for use. Read all labels carefully. DO NOT USE if they say "not suitable for use with ABS, acrylic, or polystyrene." Always rinse cleansers thoroughly within five minutes of application.

SCRATCH REMOVAL INSTRUCTIONS

1. For effective scratch removal and polishing, you will need to purchase these items.
 - 1 sheet 1000 grit 3M® wet-dry sandpaper
 - 1 sheet 1500 grit 3M® wet-dry sandpaper
 - 1 sheet 2000 grit 3M® wet-dry sandpaper
 - 1 small container of 3M® rubbing compoundThese items can be purchased at most auto supply stores that provide supplies to professional paint and body shops. Call before you go. Not all auto supply stores will have these items.
2. Start sanding with 2000 grit paper. Use small squares of paper about 2" x 2" for all sanding and use lots of water. The water serves as both a lubricant and to prevent residue buildup on the paper. Residue buildup shortens the effective life of the paper and may scratch the surface you're trying to polish.
3. 2000 grit paper is the finest grit available (the higher the number, the finer the grit). If you can't remove all of the scratches with 2000 grit, switch to 1500 grit. Remember to wash the paper frequently with water as you sand.
4. If all of the scratches can't be removed with 1500 grit, switch to 1000 grit. This should remove most fine scratches. If you have deep scratches or a gouge, coarser paper may have to be used (see chart to right). Be careful! Using grit that is too coarse may actually put in more scratches than it removes.
5. Once you have removed all of the scratches, by sanding with the finest paper possible, repeat the sanding process using successively finer grits of paper until you've once again sanded with 2000 grit.
6. Now use 3M® rubbing compound on a soft, damp cloth. Polish using considerable pressure to produce a smooth, shiny finish.



SCRATCH / SANDPAPER GUIDE

LYONS SHOWER FIXTURE — LIMITED WARRANTY

5-YEAR CONSUMER, 2-YEAR COMMERCIAL

Lyons Industries, Inc. warrants to the original purchaser that this Lyons fixture will be free of manufacturing defects, which affect its performance as a bathing or showering fixture, under the following conditions and subject to the limitations contained in the "Remedies" and "Warranty Limitations" sections. The Limited Warranty applies for 5 years from the date of purchase if the fixture is used in a residential owner-occupied building for non-commercial purposes; or for 2 years from the date of purchase if it is used in any other building, including any building used for rental, commercial, or business purposes. This Limited Warranty is void if the fixture is not installed in accordance with the installation instructions supplied by Lyons, or local building codes and ordinances, or if the care and cleaning instructions supplied by Lyons are not followed. This Limited Warranty is also void if the fixture is moved from the location of its initial installation, or is subjected to accident, abuse, or misuse. The Limited Warranty excludes normal wear and tear, and does not cover damage that can be repaired by following the Scratch Removal Instructions. This Limited Warranty shall be void unless any failure or non-conformance is discovered before the expiration of this warranty, and is reported to Lyons, in writing, accompanied by the original proof of purchase, within 30 days of discovery, to: **Lyons Industries, Inc., 30000 M-62 West, Dowagiac, Michigan 49407**

REMEDIES — The original purchaser's remedy under this Limited Warranty is limited to the repair, replacement, or refund of the purchase price of the fixture, at Lyons' sole option, of any part of the fixture which has failed or does not conform to the manufacturer's specifications. In no event shall Lyons be liable for lost profits, loss of use, incidental, special or consequential damages including, but not limited to, damage to or loss of use of the building or its contents, arising out of any defect in the fixture; nor shall Lyons be liable for any amount in excess of the original purchase price of the fixture. Lyons reserves the right to require the return, at purchaser's expense, of the damaged fixture for repair or exchange before providing services under this Limited Warranty. If Lyons elects to replace the fixture, its obligation is limited to supplying a replacement unit or component part of comparable size and style, and does not include the cost of removal, installation, or transportation, which must be borne by the purchaser. Replacement parts provided under this Limited Warranty are warranted for the remainder of the original warranty period applicable to the fixture, as if such parts were original components of that fixture.

WARRANTY LIMITATIONS — THERE ARE NO WARRANTIES WHICH EXTEND BEYOND THE DESCRIPTION ON THE FACE HEREOF. IMPLIED WARRANTIES, INCLUDING THOSE OF MERCHANTABILITY OR FITNESS FOR A PARTICULAR PURPOSE, ARE EXPRESSLY DISCLAIMED. LYONS DISCLAIMS ANY AND ALL LIABILITY FOR SPECIAL, INCIDENTAL OR CONSEQUENTIAL DAMAGES. Some states do not allow limitations of incidental or consequential damages, so the above limitations and exclusions may not apply to you. In such states, Lyons' liability shall be limited to the extent permitted by state law. ANY IMPLIED WARRANTIES ARISING BY WAY OF STATE LAW, INCLUDING ANY IMPLIED WARRANTY OF MERCHANTABILITY OR ANY IMPLIED WARRANTY OF FITNESS FOR A PARTICULAR PURPOSE, ARE LIMITED IN DURATION AND IN SCOPE OF COVERAGE TO THE TERMS OF THIS LIMITED WARRANTY, UNLESS A SHORTER PERIOD IS ALLOWED BY LAW.